	<p style="text-align: center;">TANZANIA CIVIL AVIATION AUTHORITY SAFETY REGULATION AERODROMES AND GROUND AIDS</p>	Revision: 1
Document No. TCAA/QSP/SR/AC/AGA-02	CRITERIA TO REGULATE THE USE OF A PAVEMENT BY AN AIRCRAFT WITH ACN HIGHER THAN THE REPORTED PCN (OVERLOAD OPERATIONS)	Page 1 of 4

1. PURPOSE

The purpose of this Advisory Circular is to guide aerodrome operators on the basis and procedures for establishing criteria to regulate the use of a pavement by an aircraft with an ACN higher than the PCN reported for that pavement in accordance with the Civil Aviation (Aerodromes) regulations, 2017.

2. REFERENCES

- 2.1 ICAO ANNEX 14 – Volume I, 7th Edition , July 2016
- 2.2 ICAO Doc 9157 – Part 3 (Pavements)
- 2.3 Civil Aviation (Aerodromes) Regulations, 2017

3. DESCRIPTION OF TERMS

- **Flexible Pavement**
Pavements designed and constructed using asphalt concrete placed on granular base and subbase of aggregate material or alternative composite material
- **Rigid Pavement**
Pavements designed and constructed using cement concrete material and normally act as slab in load response conditions
- **Composite Pavement**
Pavements designed and constructed using both cement concrete material and bituminous mixtures and normally assumed to act rigid pavement

4 INTRODUCTION

- 4.1 **Unrestricted Operations**
The overload control is not applicable in case where ACN is less than the PCN provided for the pavement.

	<p style="text-align: center;">TANZANIA CIVIL AVIATION AUTHORITY SAFETY REGULATION AERODROMES AND GROUND AIDS</p>	Revision: 1
Document No. TCAA/QSP/SR/AC/AGA-02	CRITERIA TO REGULATE THE USE OF A PAVEMENT BY AN AIRCRAFT WITH ACN HIGHER THAN THE REPORTED PCN (OVERLOAD OPERATIONS)	Page 2 of 4

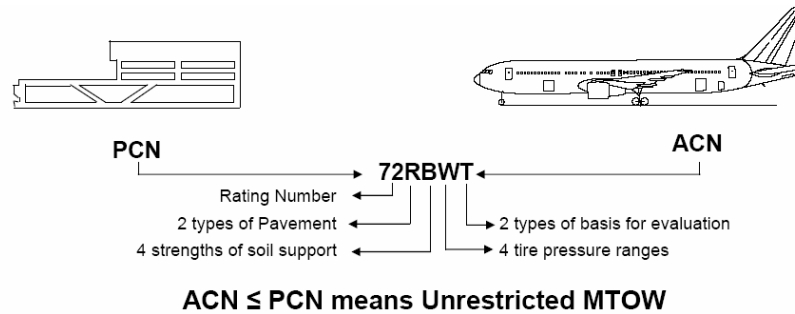

4.2 Method for Overload Operation Controls (restricted operations)

In essence, overloading of pavements can result either from loads too large, or from a substantially increased application rate, or both. Loads larger than the defined (design or evaluation) load shorten the design life, whilst smaller loads extend it. With the exception of massive overloading, pavements in their structural behaviour are not subject to a particular limiting load above which they suddenly or catastrophically fail. Behaviour is such that a pavement can sustain a definable load for an expected number of repetitions during its design life. As a result, occasional minor overloading is acceptable, when expedient, with only limited loss in pavement life expectancy and relatively small acceleration of pavement deterioration. For those operations in which magnitude of overload and/or the frequency of use do not justify a detailed analysis, the following criteria are suggested:

- (a) for flexible pavements, occasional movements by aircraft with ACN not exceeding 10 per cent above the reported PCN should not adversely affect the pavement;
- b) for rigid or composite pavements, in which a rigid pavement layer provides a primary element of the structure, occasional movements by aircraft with ACN not exceeding 5 per cent above the reported PCN should not adversely affect the pavement;

	<p style="text-align: center;">TANZANIA CIVIL AVIATION AUTHORITY SAFETY REGULATION AERODROMES AND GROUND AIDS</p>	Revision: 1
Document No. TCAA/QSP/SR/AC/AGA-02	CRITERIA TO REGULATE THE USE OF A PAVEMENT BY AN AIRCRAFT WITH ACN HIGHER THAN THE REPORTED PCN (OVERLOAD OPERATIONS)	Page 3 of 4

- c) if the pavement structure is unknown, the 5 per cent limitation should apply; and
- d) the annual number of overload movements should not exceed approximately 5 per cent of the total annual aircraft movements.

Such overload movements should not normally be permitted on pavements exhibiting signs of distress or failure.

Furthermore, overloading should be avoided during periods of heavy storms, or when the strength of the pavement or its subgrade could be weakened by water. Where overload operations are conducted, the appropriate authority should review the relevant pavement condition regularly, and should also review the criteria for overload operations periodically since excessive repetition of overloads can cause severe shortening of pavement life or require major rehabilitation of pavement.

ICAO Annex 14 volume 1 (Attachment A, section 19.1) states the criteria which shall be established to regulate the use of a pavement by an aircraft with an ACN higher than the PCN reported for that particular pavement.

4.3 Other alternative means of compliance

This guidance material draws the attention to some information that can be used by aerodrome operators to aid in establishing such criteria using the ICAO standards and recommended practice despite existence of other methods developed by states.

5 OVERLOAD OPERATIONS

- 5.1 ICAO Annex 14 Volume 1, Attachment A paragraph 19 contains some information on the ACN/PCN system including guidelines for overload operation.
- 5.2 However, the ICAO Doc 9157-AN/901 Part 3, Aerodrome Design Manual, Part 3 Pavements, contains far more information on the subject, including background explanation as well as an insight in

	<p style="text-align: center;">TANZANIA CIVIL AVIATION AUTHORITY SAFETY REGULATION AERODROMES AND GROUND AIDS</p>	Revision: 1
Document No. TCAA/QSP/SR/AC/AGA-02	CRITERIA TO REGULATE THE USE OF A PAVEMENT BY AN AIRCRAFT WITH ACN HIGHER THAN THE REPORTED PCN (OVERLOAD OPERATIONS)	Page 4 of 4

how several states have approached the subject. These are regarded as acceptable means of compliance to controlling overloading the pavements and are generally best practices in the industry which can be applied to ensure pavement preservation.

- 5.3 While the occasional marginal overload operation should not result in catastrophic damage, overload operations can affect the usable lifetime of a pavement. Significant overload operations may severely affect the lifetime of the pavement, and damage can occur, particularly with very new or already much worn pavements.

6 SUMMARY

The information contained in these documents should be used as basis for aerodrome operators to establish their system for control of overload operations and the necessary correlation with the aerodrome pavement maintenance programme.



Tanzania Civil Aviation Authority