



Advisory Circular

TCAA-AC-OPS040B

February 2020

CERTIFICATION OF AN APPROVED TRAINING ORGANISATION

1.0 PURPOSE

1.1 This Advisory Circular (AC) describes the application and certification process for obtaining an Approved Training Organisation Certificate to conduct aviation training under the Civil Aviation (Approved Training Organisation) Regulations (ATO Regulations). This AC provides basic information applicable to the certification process.

1.2 Applicants will be briefed in as much detail as necessary regarding the preparation of the Training Procedures Manual and other documents during meetings with the Authority personnel. The information in this AC and the material referenced therein will assist the applicant in completing the process with minimal delays and complications.

2.0 REFERENCES

The Civil Aviation (Approved Training Organisation) Regulations

3.0 BACKGROUND

3.1 The certification process is designed to ensure that a prospective holder of an Approved Training Organisation Certificate understands the requirements and is capable of meeting them. When satisfactorily completed, the certification process would ensure that the applicant is able to comply with the applicable requirements of ATO Regulations and the international standards applicable to the operation of an Approved Training Organisation (ATO).

3.2 The certification comprises 5 phases and 3 “gates”. A phase separates the process into related sequential activities supporting a specific function. A gate is a set of precise requirements that must be met prior to proceeding to the next phase in the process. Each phase is described in sufficient detail to provide a general understanding of the entire certification process. The five (5) phases are:

3.2.1 Pre-application;

3.2.2 Formal Application;

3.2.3 Document Evaluation;

3.2.4 Demonstration and Inspection; and

3.2.5 Certification.

3.3 An example flowchart of the certification process is at Appendix A. It is important to note that regardless of the type or complexity of the courses and training specifications applied for, the certification process will always follow the 5-phase, 3 gate processes. In some cases, the guidance and suggested sequence of events in this AC may not be entirely appropriate, for example rigid application of the gates in recertification of an existing ATO under the new Regulations. In such situations, the Authority and the



Advisory Circular

TCAA-AC-OPS040B

February 2020

applicant would proceed in a manner that considers existing conditions and circumstances. The applicant, however, should not expect to be certified until the Authority is assured that the Civil Aviation Act and pertinent Civil Aviation Regulations will be complied with in an appropriate and continuing manner.

4.0 PRE-APPLICATION PHASE

4.1 Pre-Application Statement of Intent (PASI)

4.1.1 As far in advance as possible of the anticipated start of aviation training, a prospective ATO certificate applicant should contact the Authority office and inform the Authority of his intention to apply for an ATO certificate. The prospective certificate applicant will be invited to meet briefly with the Authority personnel. During this initial meeting, only basic information and general certification requirements will be discussed. If the prospective certificate holder intends to proceed with the certification application, Form: AC-OPS001 – Pre Application Statement of Intent (PASI) will be provided to him/her. Instructions for the completion of the PASI form are at Appendix B. A sample PASI Form is at Appendix C. The PASI should be completed, signed by the prospective ATO certificate holder, and returned to the Authority Offices.

4.1.2 The Authority personnel will review the PASI. If the information is incomplete or erroneous, the PASI will be returned to the prospective ATO certificate applicant with the reasons for its return noted in section 2. If the information is complete and acceptable, the Authority will determine the team who will be assigned to the certification project and schedule a pre-application meeting with the applicant and the selected Authority certification team members.

4.1.3 The Director responsible for Safety will designate one certification team member as the Project Manager (PM).

4.1.4 The purpose of the pre-application meeting is to confirm the information on the PASI and to provide critical certification information to the applicant. It is recommended that the applicant's proposed key management staff attends the pre-application meeting and be prepared to discuss in general terms the plans and specific aspects of the proposed operation. Many problems can be avoided by discussing all aspects of the proposed operation and the specific requirements, which must be met to be certified as an ATO. Besides verifying the PASI information at the meeting, the Authority team would -

- a) Ensure that the applicant is aware of what is expected and all CARs that are applicable to the proposed training;
- b) Provide an overview of the certification process and the formal application;
- c) Answer any questions raised by the applicant;
- d) Evaluate the results of the meeting and take appropriate action;
- e) Provide the applicant with an ATO application information package.

4.1.5 The Authority considers it important to establish good working relationships and clear understanding between it, the aviation industry and persons who have an interest in aviation and aviation safety and security. The Authority recognises that a wide range of

capabilities and expertise in aviation exists in (State). Therefore, background experience of an applicant will be considered by the Authority and adjusted to during these initial meetings.

4.1.6 To help promote a clear understanding throughout the certification process, the application information package includes the following:

- a) An application form for an ATO Certificate and Training Specifications;
- b) The applicable certification checklist which will be used by the Authority inspectors during the certification project;
- c) A schedule of events (SOE) template which must be completed by the applicant and submitted with the formal application;
- d) Guidance on developing a Training Programme;
- e) A sample core curriculum;
- f) Other publications, documents and references the Authority thinks would be useful.

4.1.7 During the pre-application meeting, participating inspectors will assist the applicant in identifying all elements that accurately describe the applicant's intended operation. The applicant will then use this information to develop his draft training specifications. This information will be submitted as a part of his formal application package. The Authority certification team will guide the applicant on the application requirements.

4.1.8 If at any time during the pre-application phase the applicant formally terminates all efforts toward certification, or a period of 90 days has elapsed without any perceived activity by the applicant, or the Authority otherwise determines that the applicant will not proceed with the certification process, the PASI will be returned to the applicant. The Authority will notify the applicant in writing that this action terminates the pre-application process and that the applicant would have to submit a new PASI in order to re-initiate the certification process. Should the applicant again request to apply, a new pre-certification number will be assigned.

4.2 Application Requirements

4.2.2 ATO Regulations specifies that an applicant for an ATO certificate shall apply to the Authority in the prescribed form. The applicant must complete application Form: AC-OPS040 for an ATO Certificate and Training Specifications (See Appendix E). The completed form must be accompanied by any information the Authority requires the applicant to submit and shall be submitted to the Authority at least 90 days before the date of intended commencement of training by the applicant. The form must be signed by the Accountable Manager.

4.2.3 It is important that the applicant familiarizes himself with the relevant Parts of ATO Regulations and this AC to determine the minimum documentation necessary to be considered acceptable for a formal application. The Authority team will also give him guidance at the pre-application meeting. Regulation 5 of The Civil Aviation (Approved Training Organisations) Regulations requires that certain documents accompany the application. The required documents are as follows:

a) **Training Procedures Manual**

The purpose of the Training Procedures Manual (TPM) is to set forth the procedures and methods for the use and guidance of personnel concerned. Two copies of the Training Procedures Manual (TPM) must accompany the application. The TPM may be considered as comprising two manuals for use by the ATO personnel – a Training Manual and a Procedures Manual. The TPM may be issued as a single document or in separate parts. The ATO must have a system in place to ensure that the TPM is amended as necessary to keep the information contained therein up to date. The system must ensure that copies of all amendments to the TPM are furnished promptly to all organisations or persons to whom the manual has been distributed. The TPM must use the definitions at Appendix F and contain the following information:

- (i) A general description of the scope of training authorized under the organisation's terms of approval;
- (ii) A statement showing that the minimum qualification requirements for each management position are met or exceeded;
- (iii) A statement acknowledging that the applicant would notify the Authority within ten working days of any change made in the assignment of persons in the required management positions;
- (iv) The proposed training specifications requested by the applicant;
- (v) The proposed examination/evaluation authorization;
- (vi) A description of the flight training equipment that the applicant proposes to use where applicable;
- (vii) A description of the applicant's training facilities and equipment;
- (viii) The names, duties and qualifications of personnel to be used with responsibilities for planning, performing and supervising the training;
- (ix) A description of the procedures used to establish and maintain the competence of instructional personnel to a level acceptable to the Authority;
- (x) A training programme curriculum, including syllabi, outlines, courseware, procedures, equipment to be used and documentation;
- (xi) A description of a record keeping system that will identify and document the details of training, qualification, and licensing of students, instructors and examiners;
- (xii) A description, where applicable, of additional training required to comply with an applicant's procedures and requirements;
- (xiii) A description of quality control measures proposed to ensure that training and instructional practices comply with all relevant requirements;

Note: Appendix C gives guidance on a Quality System for an ATO

- (xiv) Where the Approved Training Organisation is authorized to conduct the testing required for the issue of an airman licence or rating, a description of the selection, role and duties of the authorized personnel*, as well as the applicable requirements established by The Civil Aviation (Personnel Licensing) Regulations, and the Authority;



Advisory Circular

TCAA-AC-OPS040B

February 2020

***Note:** The testing will be conducted by personnel authorized by the Authority or designated by the ATO in accordance with criteria approved by the Authority

(xv) A method of demonstrating the applicant's qualification and ability to provide training for a licence or rating in fewer than the minimum hours prescribed The Civil Aviation (Personnel Licensing) Regulations, if the applicant proposes to do so.

Note1: Where an aircraft is used for flight training by an ATO with flight training specifications, it must have at least two pilot stations and engine power and flight controls that are easily reached and that operate in a conventional manner from both pilot stations. The aircraft must have a valid airworthiness certificate, be maintained and inspected in accordance with the applicable Regulations requirements and must be equipped as required in the training specifications for the approved course for which it is used. Where the course of training involves IFR operations, the aircraft must be equipped and maintained for IFR operations.

Note2: Where a certificate holder contracts or otherwise engages a third party to meet any requirement, the certificate holder remains responsible for that requirement. This includes compliance with the procedures, including personnel competence, as detailed in the certificate holder's exposition.

b) **List of Training Functions to be Performed by the ATO**

The required list of training functions would be included in the TPM. This item is identified here separately to emphasize the training specifications that accompany an ATO certificate. The list should also indicate details on the type of course, the equipment used for training and which courses would result in recommendation for the issue of an airman licence under Civil Aviation (Personnel Licensing) Regulations. Since this attachment will be used for the drafting of Training Specifications it should contain sufficient detail to allow the Authority to accurately describe the applicant's intended training courses, authorizations, limitations, provisions and privileges specific to the organisation. Training specifications will contain details of the following:

- (i) The type of training authorized, including approved courses;
- (ii) The category, class, and type of aircraft that may be used for training, testing, and checking where applicable;
- (iii) For each flight simulator or flight training device, the make, model, and series of aeroplane or the set of aeroplanes being simulated and the qualification level assigned, or the make, model, and series of rotorcraft, or set of rotorcraft being simulated and the qualification level assigned;
- (iv) For each flight simulator and flight training device subject to qualification evaluation by the Authority, the identification number assigned to that equipment;
- (v) The name and address of each satellite ATO and the approved courses offered at each;
- (vi) Authorized deviations or waivers from these Regulations; and
- (vii) Any other items the Authority may require.

c) **ATO Schedule of Events Attachment**

The Schedule of Events (SOE) (See Appendix G) is a key document that lists activities, programmes, required flight training equipment, description of the applicant's training facilities, equipment, qualifications of personnel to be used, proposed evaluation plans, tool acquisitions and other requirements that must be accomplished or made ready for the Authority's inspection before certification. An SOE template is provided as part of the application package. The applicant will enter the estimated date and timelines in consultation with his management team and the Authority. The estimated dates in the SOE must be logical in terms of sequence. Reasonable time for the Authority to review, inspect and approve each item or event should also be provided when approval is required before beginning a subsequent event or item. Failure to accomplish an item or event in a satisfactory manner or in accordance with the SOE could delay the certification. If at any time during the certification process the applicant finds it necessary to revise the SOE, the Authority should be notified as soon as possible. There will be a process of negotiation between the Authority and the applicant to agree certain items in the SOE with respect to certification timelines.

d) **Statement of Compliance**

This attachment is a document showing how the applicant intends to comply with the relevant Civil Aviation Regulations applicable to the proposed training operations. Pertinent regulations, sub regulations, and each relevant section of any schedules should be identified and accompanied by a brief description, or preferably a specific reference, in the applicant's manuals or other documents. The brief description or reference must describe the method of compliance for each regulation or schedule listed. If the precise method of compliance has not been developed at the time of formal application, an indication of the date that this information will be provided will be satisfactory at this point, if the date provided is reasonable and acceptable to the Authority. Appendix H is one example of how relevant sections of the Regulations may be presented in a Statement of Compliance. This AC gives other acceptable options for completing a compliance statement.

e) **Documents of Purchase, Leases, Contracts, or Letters of Intent Attachments**

These attachments should provide evidence that the applicant is in the process of actively procuring facilities, equipment and tools, aircraft, and equipment manuals and services appropriate to training functions to be performed and the training specifications requested. If formal contracts are not completed, letters or other documents showing preliminary agreements or intent will suffice until such date as determined by the Authority when the final valid documents must be presented for the certification process to proceed. The facilities, equipment, tools and other support items must be of such type that support the training specifications requested. These documents may be attachments to the Training Procedures Manual (TPM).

f) **Resumes of key Management Personnel, Instructors and Examiners**

Appendix I is a sample biographical data form which would accompany the resumes of key management personnel, instructors and examiners.



Advisory Circular

TCAA-AC-OPS040B

February 2020

g) **Completed Vital Information Data Forms.**

These forms contain information on names, addresses and contact numbers of key personnel, facilities and functions which need to be completed by the applicant.

4.0 FORMAL APPLICATION PHASE

4.1 The formal application must be submitted on form TF-071 at least 90 days before training is planned to begin, although preferably it should be submitted to the Authority more than 90 days and as far in advance of the proposed start-up date as possible. The form must be accompanied by all the required Appendices and attachments. The information required in the Appendices is shown at block 5 of the application form. Each Appendix applicable to the training specifications must be identified by the Appendix letter shown for that item on the application form.

4.2 The Authority will review the application to determine that it contains the required information and attachments. If there are major omissions or errors, the formal application and all attachments will be returned with a letter outlining the reasons for its return. If the applicant has a good understanding of the requirements, the formal application should be of sufficient quality to allow any omission or open question to be resolved during the formal application meeting.

4.3 The formal application meeting would reinforce open communication and working relationships. The applicant's key management personnel would be expected to attend the formal application meeting. The purpose of this meeting is to discuss the formal application and resolve omissions, deficiencies and open questions. Date conflicts on the SOE would also be resolved here. Subsequent phases of the certification process will be fully discussed. The applicant should seek clarification of any item or event that is not clearly understood. The Authority would respond to any questions the applicant may have and reinforce the certification process. Based upon the results of the meeting, the Authority certification team will determine the acceptability of the application package, but the PM will not formally accept the application during the meeting. This delay allows the prospective certificate holder time to resolve any omissions or any discrepancies discussed during the meeting.

4.4 The applicant will be notified by letter stating whether the formal application is accepted or denied. The Authority acceptance of a formal application does not constitute approval or acceptance of individual attachments. These documents will be evaluated thoroughly during subsequent phases of the certification process. If the formal application is not acceptable, it will be returned with all attachments and a written explanation of the reasons for its return.

5.0 DOCUMENT EVALUATION PHASE

5.1 After the formal application has been accepted, inspectors will begin a thorough evaluation of –

5.1.1 The qualifications of management, training and quality control personnel;

- 5.1.2 Training Curricula and their assessments;
- 5.1.3 All the manuals and documents that have been submitted to the Authority in support of the application;
- 5.1.4 Aircraft lease contracts where applicable;
- 5.1.5 Final compliance statement.

5.2 The Authority will endeavour to complete these evaluations in accordance with the applicant's SOE. If a manual or document is incomplete or deficient, or if non-compliance with the regulations or safe operating practices is detected, the manual or document will be returned for corrective action. If the manual or document is satisfactory, it will be approved or accepted, as required by ATO Regulations. Approvals will be indicated by letter or by initial approval of specific Training Specifications where appropriate. Acceptance of information that does not require formal approval will be indicated by letter or by lack of the Authority's objection to the information.

5.3 The initial Statement of Compliance which was submitted with the formal application should have progressed to a final Statement of Compliance by the end of the document evaluation phase. The fully completed final Statement of Compliance ensures that each applicable regulatory requirement has been adequately addressed in the appropriate manual, programmes and procedures.

6.0 DEMONSTRATION AND INSPECTION PHASE

6.1 An applicant will need to demonstrate his ability to comply fully with the regulations before beginning operations. These demonstrations include actual performance of activities and/or operations while being observed by Authority Inspectors. This includes on-site evaluations of at least the following:

- 6.1.1 Aircraft proposed for conduct of training as applicable;
- 6.1.2 Flight simulator and training devices as applicable;
- 6.1.3 Training facilities and training equipment;
- 6.1.4 Training curricula;
- 6.1.5 Training in progress;
- 6.1.6 Testing and examinations;
- 6.1.7 Record keeping system;
- 6.1.8 Quality Control system.

6.2 During these demonstrations and inspections, the Authority evaluates the effectiveness of the policies, methods, procedures, and instructions as described in the applicant's manual and other documents. Emphasis is placed on the applicant's management of systems, quality control and overall management and training effectiveness during this phase.



Advisory Circular

TCAA-AC-OPS040B

February 2020

Discrepancies will be brought to the attention of the applicant and corrective action must be taken before a certificate is issued.

7.0 CERTIFICATION PHASE

After the document evaluation and demonstration and inspection phases have been completed satisfactorily, the Authority will prepare the ATO Certificate and approve the Training Specifications. The Training Specifications contain the courses, authorizations, limitations, and provisions specific to the certificate holder's operation. The certificate holder must acknowledge receipt of these documents.

8.0 SURVEILLANCE

After certification of an ATO, the Authority is responsible for conducting periodic inspections of its operations to ensure continued compliance with the Regulations, the provisions of the ATO certificate and training specifications and safe operating practices. The Authority may also carry out spot checks of the operations of an ATO to determine whether it continues to comply with the Regulations. Such spot checks will generally be of short duration to minimize any disruption to the certificate holder's activities.

9.0 RENEWAL OF AN ATO CERTIFICATE

The ATO certificate is valid for 12 months. An application for renewal of an ATO certificate will be submitted on Form TF-071 to the Authority at least 30 days before the expiration date of the existing ATO certificate. The Authority will conduct a formal audit of the ATO to ensure that it continues to meet the certification requirements. If the audit is successful, the ATO Certificate and applicable training specifications will be renewed.

10.0 AMENDMENT OF AN ATO CERTIFICATE

10.1 The ATO must continually be in compliance with the ATO Regulations, other relevant Regulations, and the authorizations, and provisions of its certificate and training specifications. Where the Authority determines that an ATO is not meeting the requirements of a curriculum specified in its Training Procedures Manual, the Authority may direct the certificate holder to amend the curriculum.

10.2 As an ATO's operation changes, the ATO may apply to the Authority for amendment of its training specifications. The process for amending training specifications is similar to the certification process. In some cases it may be a less complex procedure depending on the subject of the amendment.

11.0 SATELLITE ATO

If an ATO certificate holder proposes to conduct training at a facility other than his main base of operations, the Authority must be notified in writing at least 60 days prior to the proposed commencement of operations at the proposed satellite location. The facilities, equipment, personnel and course content of the ATO must meet the applicable

requirements for the issue of training specifications to conduct specific training at that satellite location.

12.0 CHANGES TO AN ATO

12.1 An ATO must give the AUTHORITY at least 30 days' notification of the following:

12.1.1 The appointment of a new accountable manager, or

12.1.2 quality manager or;

12.1.3 Change of any training instructor or examiner; or

12.1.4 Variation or changes of housing, training facilities and equipment, procedures, curricula or work scope which might potentially affect its training specifications.

12.2 The Authority may prescribe the conditions under which the ATO may operate during such changes, or may determine that suspension of the ATO Certificate would be more appropriate.

12.3 An ATO must give the Authority at least 10 working days' notice of any changes made in the assignment of persons in the required management positions.

13.0 EXPLANATION OF APPENDICES IN THIS AC

13.1 The following Appendices accompany this document:

13.1.1 Appendix A is an example Certification Process Flow Chart;

13.1.2 Appendix B provides instructions on how the Authority; Prospective ATO Pre-Assessment Statement of Intent (PASI) should be completed;

13.1.3 Appendix C is a sample PASI form;

13.1.4 Appendix D provides guidance on a Quality System for an ATO;

13.1.5 Appendix E is a sample application form for the issue of an Approved Training Organisation Certificate;

13.1.6 Appendix F is a list of definitions of some key terms used in ATO certification;

13.1.7 Appendix G is a sample of an ATO certification checklist and SOE;

13.1.8 Appendix H is an example of a compliance statement;

13.1.9 Appendix I is a sample Biographical Data Form;

13.1.10 Appendix J is a sample of training specifications.

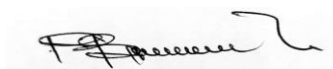
A handwritten signature in black ink, appearing to read 'P. J. Macneil', is written over a light blue horizontal line.

Director Safety Regulation



Advisory Circular

TCAA-AC-OPS040B

February 2020

APPENDIX A Certification Process Flowchart Page 1 of 5



Advisory Circular

TCAA-AC-OPS040B

February 2020

Page 1 of 5
The flow charts on the following pages are representative of the ATO Certification Process. This chart also represents the process for the certification of an ATO.

PRE-APPLICATION PHASE ATO CERTIFICATION PROCESS

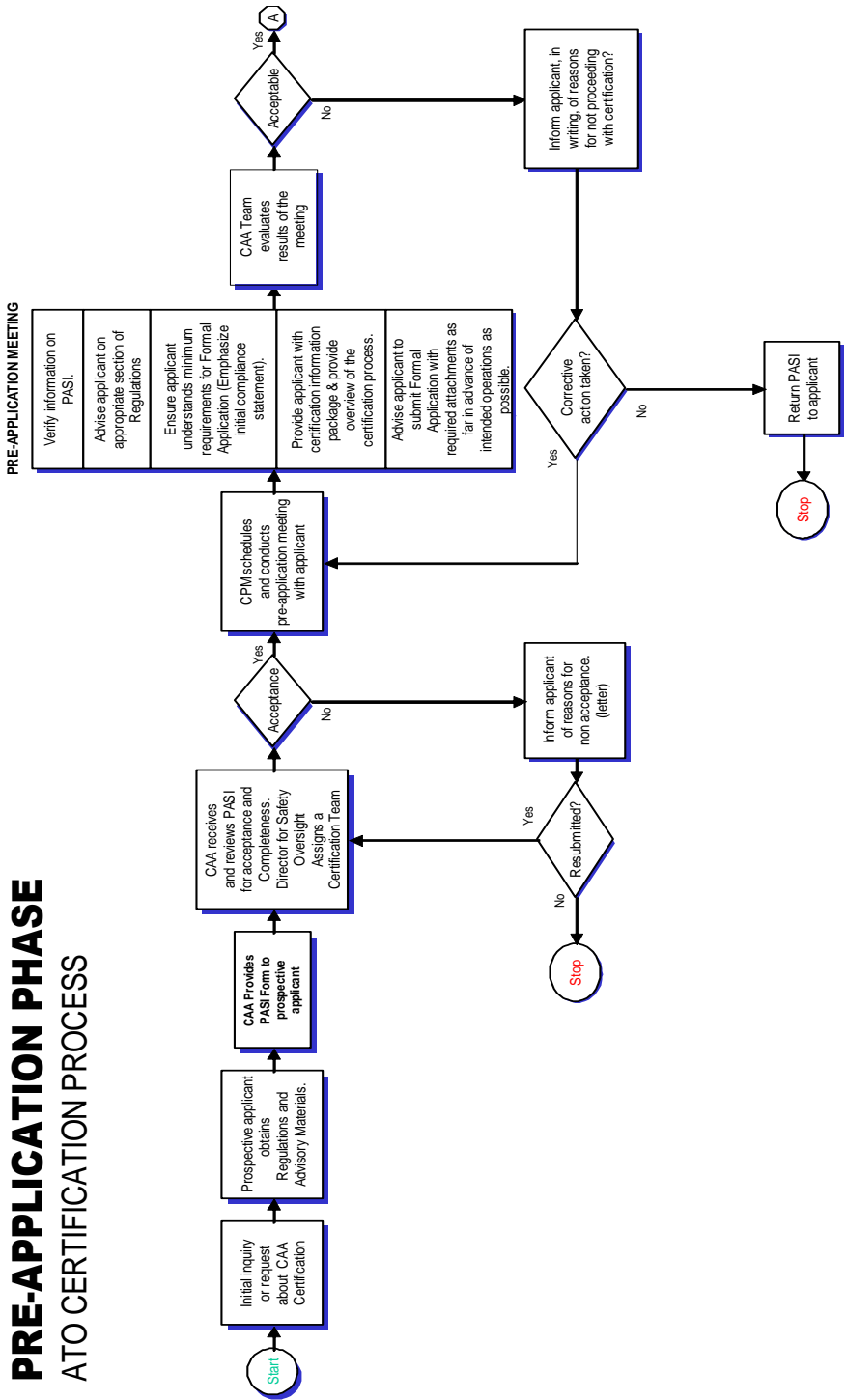



Advisory Circular

TCAA-AC-OPS040B

February 2020

Appendix A -
Certification Process
Flow Chart.
Page 2 Of 5

FORMAL APPLICATION PHASE ATO PROCESS

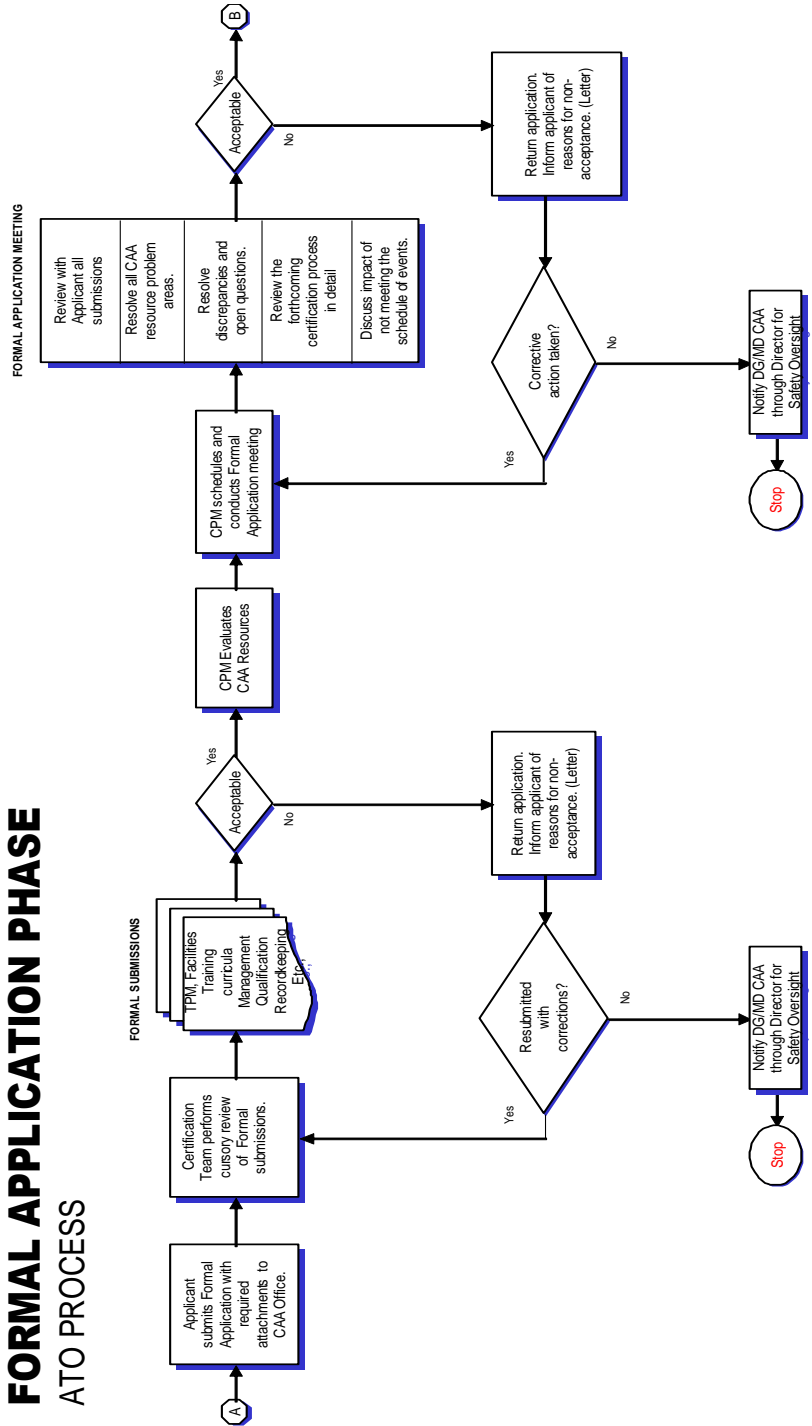



Advisory Circular

TCAA-AC-OPS040B

February 2020

Appendix A -
Certification Process
Flow Chart.
Page 3 of 5

DOCUMENT EVALUATION PHASE ATO PROCESS

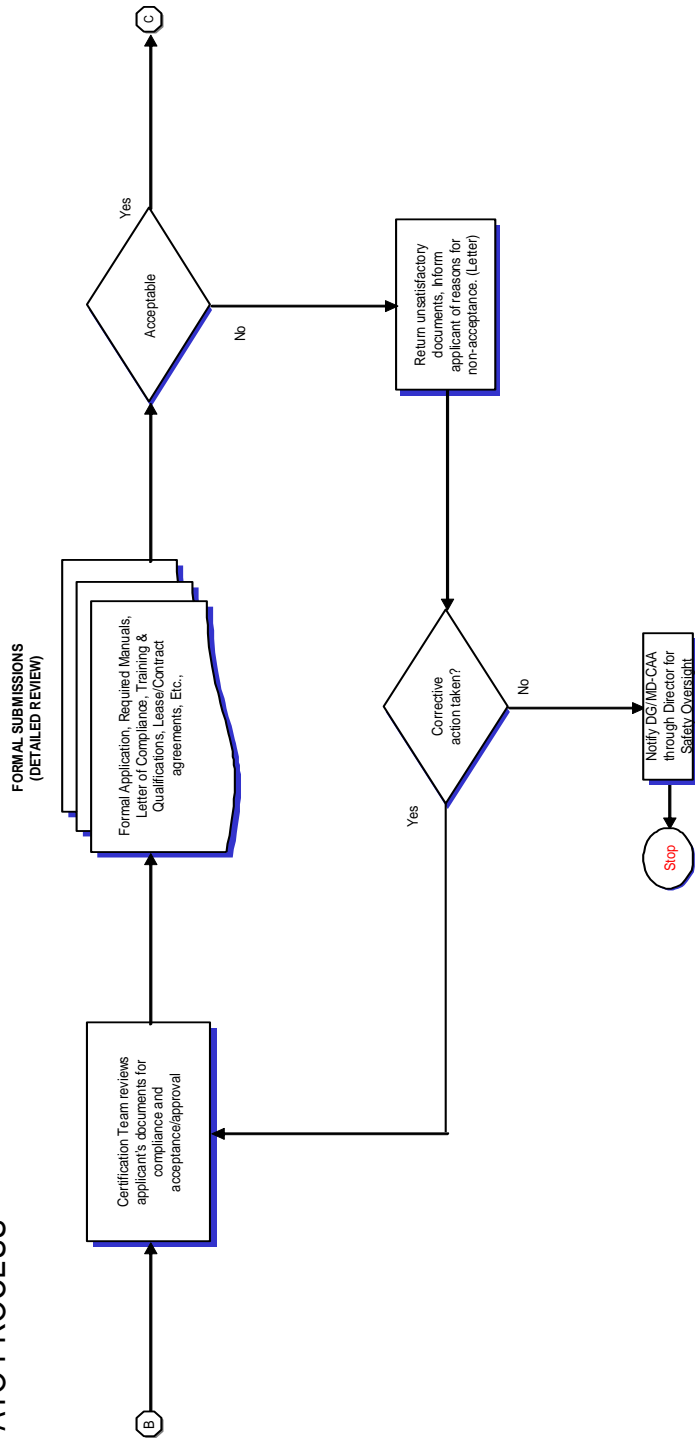



Advisory Circular

TCAA-AC-OPS040B

February 2020

Appendix A -
Certification Process
Flow Chart.
Page 4 of 5

DEMONSTRATION AND INSPECTION PHASE ATO PROCESS

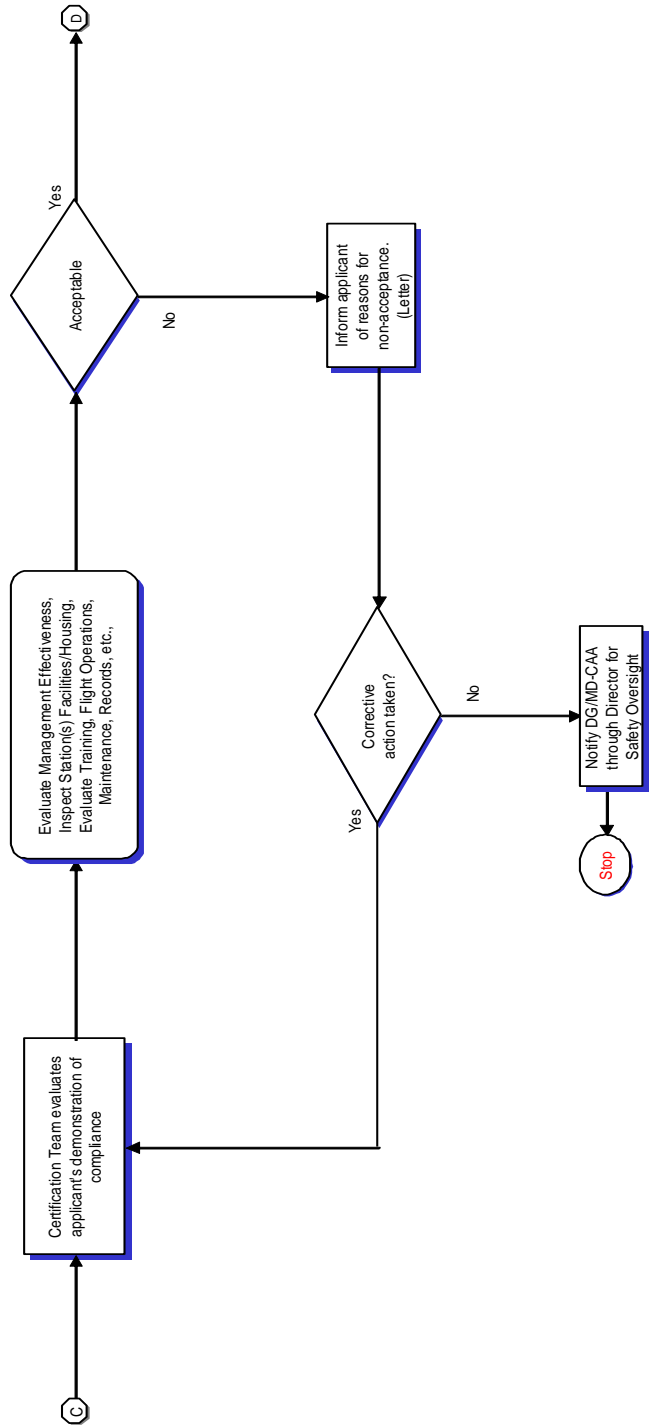



Advisory Circular

TCAA-AC-OPS040B

February 2020

Appendix A -
Certification Process
Flow Chart.
Page 5 of 5

CERTIFICATION PHASE ATO PROCESS

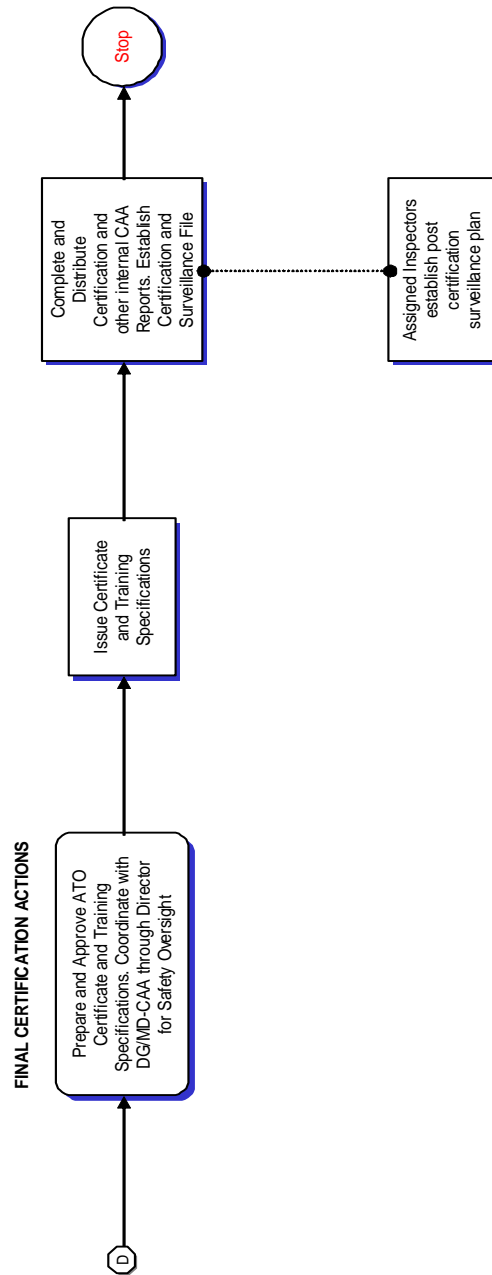



Advisory Circular

TCAA-AC-OPS040B

February 2020

Appendix B

INSTRUCTIONS FOR COMPLETING FORM: AC-OPS040A – PROSPECTIVE ATO PRE-ASSESSMENT STATEMENT (PASI)

(To be completed by an applicant for an ATO Certificate)

SECTION 1A:

1. Enter the company's official name and mailing address. Include any other business name if different from the company name).
2. Provide the address of the main base of operations. It is where the offices of management required by regulation are located. If the address is the same as in item 1, enter "same." State secondary business addresses (if applicable) of operation and identify the type of operation conducted at each address.
3. Provide the address of any Satellite Training Organisation.
4. Identify the training that will be conducted at the satellite ATO.
5. Enter the estimated commencement date of operations.
6. The information provided in this block in (1), (2), or (3) will be used to assign a company designator. The applicant may indicate up to three (3), 3-letter identifiers, such as ABC, XYZ, etc. If all choices have been assigned to another ATO, a randomly selected or next available 3-letter identifier will be assigned.
7. Enter the names, titles, and telephone numbers of management personnel.

SECTION 1B:

8. The proposed type of ATO training specifications shall be indicated. Check as many boxes as applicable. Refer to Appendix I for examples of training specifications. If the proposed training is not listed, it must be specified in the blank field with additional detail provided in block 10 where necessary.

SECTION 1C:

9. Identify the type of aircraft and/or simulators.
An applicant for an ATO Certificate with flight training specifications should identify the type of aircraft to be used for training by make, model and Series and the number of units of each type. Where a flight simulator is to be used, details of the simulator are to be provided. Additional details on aircraft and simulators should be entered in block 11.



Advisory Circular

TCAA-AC-OPS040B

February 2020

SECTION 1D

- 10. Show any information that would assist Authority personnel in understanding the type and scope of operation or services to be performed by the applicant. If an applicant intends to arrange for maintenance and inspections of his aircraft and/or associated equipment, identify the AMO selected and a list of the maintenance or inspections he proposes to perform. Also provide copies of all written contracts with this form, if applicable. An applicant for an ATO Certificate should identify prospective maintenance contractors he intends to use and their locations.
- 11. The Prospective ATO Pre-Assessment Statement (PASI) denotes intent to seek Authority certification as an ATO. It must be signed as follows:

<u>Type of Organisation</u>	<u>Authorized Signature</u>
Individual,	Owner,
Partnership	At least one partner,
Company, corporation, association, etc	At least one authorized officer

Regulation 17 - of the Civil Aviation (Approved Training Organisation) Regulations must sign the PASI Form. If the PASI Form is signed by another individual who is not the Accountable Manager the Accountable Manager must submit with the PASI Form a letter authorizing the signatory to sign on his behalf.

5.0 SECTIONS 2 – For Authority use

The prospective applicant must address this PASI form to the Office of the Director General of Civil Aviation. Upon receipt of the PASI the fields in this section is filled out. The form is then forwarded to the Director responsible for Safety oversight.

6.0 SECTIONS 3 – For Authority use

Upon receipt of the PASI the Office of the Director responsible for Safety oversight will fill out the fields in this section. The Director will complete the “Pre-application number”, “Assigned Project Manager” and the date the completed form was forwarded to the assigned PM. The “Assigned Certification Number” field will be filled out during the Certification Phase of the ATO.



Advisory Circular

TCAA-AC-OPS040B

February 2020

APPENDIX C PROSPECTIVE ATO PRE-ASSESSMENT STATEMENT (PASI)

Prospective ATO Pre-assessment Statement (PASI) (To be completed by an applicant for an ATO Certificate)				
Section 1A. Name and Key Personnel				
1. Name and mailing address of company (include business name if different from company name).		2. Address of the principal (main) base where operations will be conducted.		
3. Address of Satellite Location for the conduct of specific training.		4. Training Specifications requested at each Satellite Location:		
5. Proposed Start-up Date:		6. Requested company identifier in order of preference. (1) (2) (3)		
7. Management and Key Personnel.				
Name (Surname/First/Middle Initial)			Proposed position in the ATO	Telephone & address (if different from company include country code)
Surname	First Name	MI		
			Accountable Manager	
			Chief Instructor	
			Quality Manager	
Section 1B. Proposed Courses of Instruction				
8. Applicant intends to conduct: (Tick as required)				
<input type="checkbox"/> Pilot Training with Level 1 Flight Training Specifications				
<input type="checkbox"/> Pilot Training with Level 2 Flight Training Specifications				
<input type="checkbox"/> Aircraft Maintenance Personnel Training				
<input type="checkbox"/> Flight Operations Officer Training				
<input type="checkbox"/> Air Traffic Services Training				
<input type="checkbox"/> Cabin Crew Training				
<input type="checkbox"/> Aviation Security Personnel Training				
<input type="checkbox"/> Ground Services Personnel Training				
<input type="checkbox"/> Material Handler Training				
<input type="checkbox"/> _____ Training* as an ATO (*Specify training)				
Section 1C. Aircraft and Simulator Information (to be completed by Prospective Pilot Training ATO and prospective Maintenance Training ATO).				



Advisory Circular

TCAA-AC-OPS040B

February 2020

9. Aircraft Data (Simulator Information	
		[Authority Assigned ID] :	
Aircraft Type (M/M/S).	Number of Aircraft Type	Make, model and series of aircraft being simulated	Qualification Level Assigned

AC-OPS040A

Section 1D. ADDITIONAL INFORMATION

10. Additional information that provides a better understanding of the proposed operation or business (Attach additional sheets, if necessary).

11. Proposed Training (Aircraft and/or Simulator).

12. The statement and information contained on this form denotes an intention to apply for a Authority Certificate for the operation of an ATO.

Name and Title (Block Letters)	Signature	Date (dd/mm/yy).
--------------------------------	-----------	------------------

SECTION 2. TO BE COMPLETED BY DIRECTOR FLIGHT SAFETY OFFICE.

Received by (Name and Office):	Date received (dd/mm/yy)
--------------------------------	--------------------------

Assigned Project Manager:

Date forwarded to Manager Flight Operations (dd/mm/yy).	For: <input type="checkbox"/> Action <input type="checkbox"/> Information only.
---	---

Remarks:



Advisory Circular

TCAA-AC-OPS040B

February 2020

SECTION 3. To be completed by the Office of the Manager Flight Operations

Received by:		Date (dd/mm/yy).	
Pre-application Number:		Assigned Certification Number:	
Assigned FOI:		Date:	
Remarks:			

AC-OPS040A

APPENDIX D

QUALITY SYSTEM FOR AN ATO

1.0 PURPOSE

1.1 This guidance material provides information and guidance to an ato applicant on how to establish a quality system that satisfies the quality control standards required to ensure that training and instructional practices comply with all relevant requirements.

1.2 A basis for quality should be established by every ato and problem-solving techniques should be applied for the running of processes. Knowledge on how to measure, establish and ultimately achieve quality in training and education is essential.

2.0 TERMINOLOGY

2.1 The following terms and definitions when used in the context of this AC have the meanings shown:

2.1.1 **Quality** – The totality of features and characteristics of a product or service that bear on its ability to satisfy stated or implied needs.

2.1.2 **Quality Assurance** – All those planned and systematic actions necessary to provide adequate confidence that all training activities satisfy given requirements including the ones specified by the ATO in relevant manuals.

2.1.3 **Quality Manual** – The document containing the relevant information pertaining to the ATO's quality system and quality assurance program.

2.1.4 **Quality audit** – A systematic and independent examination to determine whether quality activities and related results comply with planned arrangements and whether these arrangements are implemented effectively and are suitable to achieve objectives.

3.0 ELEMENTS OF AN ATO QUALITY SYSTEM

3.1 The following five elements should be clearly identifiable in the quality system of an ATO approved for the conduct of training for licences and ratings:

3.1.1 Determination of the Organisation's training policy and training and flight safety standards;

3.1.2 Determination and establishment of assignment of responsibility, resources, Organisation and operational processes, which will make allowance for policy and training and flight safety standards;

- 3.1.3 Follow up system to ensure that policy, training and flight safety standards are complied with;
- 3.1.4 Registration and documentation of deviations from policy, training and flight safety standards together with necessary analysis, evaluations and correction of such deviations; and
- 3.1.5 Evaluation of experiences and trends concerning policy, training and flight safety standards.

4.0 QUALITY POLICY AND STRATEGY

- 4.1 It is of vital importance that the ATO describes how the Organisation formulates, deploys and reviews its policy and strategy and turns it into plans and actions. A formal written Quality Policy Statement should be established that is a commitment by the Head of Training, as to what the Quality System is intended to achieve. The Quality Policy should reflect the achievement and continued compliance with relevant parts of Civil Aviation (Personnel Licensing) Regulations and ATO Regulations together with any additional standards specified by the ATO or the Authority.
- 4.2 The Accountable Manager will have overall responsibility for the Quality System including the frequency, format and structure of the internal management evaluation activities.

5.0 PURPOSE OF A QUALITY SYSTEM

The implementation and employment of a Quality System will enable the ATO to monitor compliance with relevant parts of Civil Aviation (Personnel Licensing) Regulations and ATO Regulations, the TPM, and any other standards as established by the ATO or the Authority to ensure safe and efficient training.

6.0 QUALITY MANAGER

- 6.1.1 The primary role of the Quality Manager is to verify, by monitoring activities in the field of training, that the standards required by the Authority and any additional requirements as established by the ATO are being carried out properly under the supervision of the Head of Training, Chief Flight Instructor and Chief Ground Instructor as applicable.
- 6.1.2 The Quality Manager should be responsible for ensuring that the Quality Assurance Program is properly implemented, maintained and continuously reviewed and improved. The Quality Manager should:
 - 6.1.3 have direct access to the Head of Training;
 - 6.1.4 have access to all parts of the ATO's Organisation.

6.1.5 In the case of small or very small ATO's, the posts of the Head of Training and the Quality manager may be combined. However, in this event, quality audits should be conducted by independent personnel.

7.0 QUALITY SYSTEM

7.1 General

7.1.1.1 The Quality System of the ATO should ensure compliance with and adequacy of training activities conducted.

7.1.1.2 The ATO should specify the basic structure of the Quality System applicable to all training activities conducted.

7.1.1.3 The Quality System should be structured according to the size of the ATO and the complexity of the training to be monitored.

7.2 Scope

7.2.1 A quality System should address the following:

- a) Leadership;
- b) Policy and Strategy;
- c) Processes;
- d) The provisions of Part 2 and 3;
- e) Additional standards and training procedures as stated by the ATO;
- f) The Organisational structure of the ATO;
- g) Responsibility for the development, establishment and management of the Quality System;
- h) Documentation, including manuals, reports and records;
- i) Quality Assurance Program;
- j) The required financial, material and human resources;
- k) Training requirements;
- l) Customer satisfaction.

7.3 Feedback System

The quality system should include a feedback system to ensure that corrective actions are both identified and promptly addressed. The feedback system should also specify who is required to rectify discrepancies and non-compliance in each particular case, and the procedure to be followed if corrective action is not completed within an appropriate timescale.

7.4 Documentation

7.4.1.1 Relevant documentation includes the relevant part(s) of the Training and Procedures Manual, which may be included in a separate Quality Manual.

7.4.2 In addition, relevant document should also include the following:

- a) Quality Policy;
- b) Terminology;
- c) Specified training standards;
- d) A description of the Organisation;
- e) The allocation of duties and responsibilities;
- f) Training procedures to ensure regulatory compliance.

7.4.3 The Quality Assurance Program, reflecting:

- a) Schedule of the monitoring process;
- b) Audit procedures;
- c) Reporting procedures;
- d) Follow-up and corrective action procedures;
- e) Recording System;
- f) The training syllabus;
- g) Document control.

7.5 Quality Assurance Program

The Quality Assurance Program should include all planned and systematic actions necessary to provide confidence that all training is conducted in accordance with all applicable requirements, standards and procedures.

7.6 Quality Inspection

7.6.1.1 The primary purpose of a quality inspection is to observe a particular event/action/document etc., in order to verify whether established training procedures and requirements are followed during the accomplishment of that event and whether the required standard is achieved.

7.6.2 Typical subject areas for quality inspections are:

- (a) Actual flight and ground training;
- (b) Maintenance;
- (c) Technical Standards;
- (d) Training Standards.

7.7 Audit

7.7.1.1 An audit is a systematic and independent comparison of the way in which training is being conducted against the way in which the published training procedures say it should be conducted.

7.7.2 Audits should include at least the following quality procedures and processes:

- a) An explanation of the scope of the audit;
- b) Planning and preparation;
- c) Gathering and recording evidence;
- d) Analysis of the evidence.

7.7.3 The various techniques that make up an effective audit are:

- a) Interviews or discussions with personnel;
- b) A review of published documents;
- c) The examination of an adequate sample of records;
- d) The witnessing of the activities which make up the training;
- e) The preservation of documents and the recording of observations.

7.8 Auditors

7.8.1.1 The ATO should decide, depending on the complexity of the training, whether to make use of a dedicated audit team or a single auditor. In any event, the auditor or audit team should have relevant training and/or operational experience.

7.8.1.2 The responsibilities of the auditors should be clearly defined in the relevant documentation.

7.9 Auditor's Independence

7.9.1.1 Auditors should not have any day-to-day involvement in the area of the operation or maintenance activity which is to be audited. An ATO may, in addition to using the services of full-time dedicated personnel belonging to a separate quality department, undertake the monitoring of specific areas or activities by the use of part-time auditors.

7.9.1.2 An ATO whose structure and size does not justify the establishment of full-time auditors, may undertake the audit function by the use of part-time personnel from within its own Organisation or from an external source under the terms of an agreement acceptable to the Authority.

7.9.1.3 In all cases the ATO should develop suitable procedures to ensure that persons directly responsible for the activities to be audited are not selected as part of the auditing team. Where external auditors are used, it is essential that any external specialist is familiar with the type of training conducted by the ATO.

7.9.1.4 The Quality Assurance Program of the ATO should identify the persons within the company who have the experience, responsibility and Authority to:

- a) Perform quality inspections and audits as part of ongoing Quality Assurance;
- b) Identify and record any concerns or findings, and the evidence necessary to substantiate such concerns or findings;
- c) Initiate or recommend solutions to concerns or findings through designated reporting channels;
- d) Verify the implementation of solutions within specific timescales;
- e) Report directly to the Quality Manager;

7.10 Audit Scope

ATOs are required to monitor compliance with the Training and Procedures Manuals they have designed to ensure safe and efficient training. In doing so they should as a minimum, and where appropriate, monitor:

- a) Organisation;
- b) Plans and objectives;
- c) Training Procedures;
- d) Flight Safety;
- e) Manuals, Logs and Records;
- f) Flight and Duty Time limitations;
- g) Rest requirements and scheduling;
- h) Aircraft Maintenance/Operations interface;
- i) Maintenance programs and continued airworthiness;
- j) Maintenance accomplishment;

7.11 Audit Scheduling

7.11.1 A Quality Assurance Program should include a defined audit schedule and a periodic review cycle. The schedule should be flexible, and allow unscheduled audits when trends are identified. Follow-up audits should be scheduled when necessary to verify that corrective action was carried out and that it was effective.

7.11.2 An ATO should establish a schedule of audits to be completed during a specific calendar period. All aspects of the training should be reviewed within a period of 12 months in accordance with the program unless an extension to the audit period is accepted as explained below.

7.11.3 An ATO may increase the frequency of their audits at their discretion but should not decrease the frequency without the acceptance of the Authority. It is considered unlikely that a period greater than 24 months would be acceptable for any audit topic.

7.11.4 When an ATO defines the audit schedule, significant changes to the management, Organisation, training, or technologies should be considered, as well as changes to the regulatory requirements.

7.12 Monitoring and corrective action

- 7.12.1 The aim of monitoring within the Quality System is primarily to investigate and judge its effectiveness and thereby to ensure that defined policy, training standards are continuously complied with. Monitoring activity is based upon quality inspections, audits, corrective action and follow-up. The ATO should establish and publish a quality procedure to monitor regulatory compliance on a continuing basis. This monitoring activity should be aimed at eliminating the causes of unsatisfactory performance.
- 7.12.2 Any non-compliance identified should be communicated to the manager responsible for taking corrective action or, if appropriate, the Accountable Manager. Such non-compliance should be recorded, for the purpose of further investigation, in order to determine the cause and to enable the recommendation of appropriate corrective action.
- 7.12.3 The Quality Assurance Program should include procedures to ensure that corrective actions are developed in response to findings. These quality procedures should monitor such actions to verify their effectiveness and that they have been completed. Organisational responsibility and accountability for the implementation of corrective action resides with the department cited in the report identifying the finding. The Accountable Manager will have the ultimate responsibility for ensuring, through the Quality Manager(s), that corrective action has re-established compliance with the standard required by the Authority and any additional requirements established by the ATO.

7.13 Corrective Action

- 7.13.1 Subsequent to the quality inspection/audit, the ATO should establish:
- The seriousness of any findings and any need for immediate corrective action;
 - The origin of the finding;
 - What corrective actions are required to ensure that the non-compliance does not recur;
 - A schedule for corrective action;
 - The identification of individuals or departments responsible for implementing corrective action;
 - Allocation of resources by the Accountable Manager, where appropriate.
- 7.13.2 The Quality Manager should:
- Verify that corrective action is taken by the manager responsible in response to any finding of non-compliance;
 - Verify that corrective action includes the elements outlined in paragraph (16) above;
 - Monitor the implementation and completion of corrective action;
 - Provide management with an independent assessment of corrective action, implementation and completion;
 - Evaluate the effectiveness of corrective action through the follow-up process.

7.14 Management Evaluation

A management evaluation is a comprehensive, systematic documented review by the management of the quality system, training policies, and procedures, and should consider the results of quality inspections, audits and any other indicators; as well as the overall effectiveness of the management Organisation in achieving stated objectives. A management evaluation should identify and correct trends, and prevent, where possible, future non-conformities. Conclusions and recommendations made as a result of an evaluation should be submitted in writing to the responsible manager for action. The responsible manager should be an individual who has the Authority to resolve issues and take action. The Accountable Manager should decide upon the frequency, format, and structure of internal management evaluation activities.

7.15 Recording

- 7.15.1 Accurate, complete and readily accessible records documenting the result of the Quality Assurance Program should be maintained by the ATO. Records are essential data to enable an ATO to analyse and determine the root causes of non-conformity, so that areas of non-compliance can be identified and subsequently addressed.
- 7.15.2 The following records should be retained for a period of 5 years: Regulation 11 (3) of the Civil Aviation (Approved Training Organisations) Regulations:
- (a) Audit schedules;
 - (b) Quality inspection and audit reports;
 - (c) Responses to findings;
 - (d) Corrective action reports;
 - (e) Follow-up and closure reports;
 - (f) Management evaluation reports.

7.16 Quality Assurance Responsibility for Satellite ATOs

- 7.16.1 An ATO may decide to sub-contract out certain activities to external Organisations subject to the approval of the Authority.
- 7.16.2 The ultimate responsibility for the training provided by the satellite ATO always remains with the ATO. A written agreement should exist between the ATO and the satellite ATO clearly defining the safety related services and quality to be provided. The satellite ATO's safety related activities relevant to the agreement should be included in the ATO's Quality Assurance Program.
- 7.16.2.1 The ATO should ensure that the satellite ATO has the necessary authorisation/approval when required, and commands the resources and competence to undertake the task. If the ATO requires the satellite ATO to conduct activity which exceeds the satellite ATO's authorisation/approval, the ATO is responsible for ensuring that the satellite ATO's quality assurance takes account of such additional requirements.

7.17 Quality System Training

7.17.1.1 Correct and thorough training is essential to optimise quality in every Organisation. In order to achieve significant outcomes of such training the ATO should ensure that all staff understand the objectives as laid down in the Quality Manual.

7.17.2 Those responsible for managing the Quality System should receive training covering:

- a) An introduction to the concept of Quality System;
- b) Quality management;
- c) Concept of Quality Assurance;
- d) Quality manuals;
- e) Audit techniques;
- f) Reporting and recording;
- g) The way in which the Quality System will function in the ATO.

7.17.2.1 Time should be provided to train every individual involved in quality management and for briefing the remainder of the employees. The allocation of time and resources should be governed by the size and complexity of the operation concerned.

7.18 Quality Systems for Small/Very Small Organisations

7.18.1.1 The requirement to establish and document a Quality System and to employ a Quality Manager applies to all ATOs.

7.18.1.2 Complex quality systems could be inappropriate for small or very small ATOs and the clerical effort required drawing up manuals and quality procedures for a complex system may stretch their resources. It is therefore accepted that such ATOs should tailor their quality systems to suit the size and complexity of their training and allocate resources accordingly.

7.18.1.3 For small and very small ATOs it may be appropriate to develop a Quality Assurance Program that employs a checklist. The checklist should have a supporting schedule that requires completion of all checklist items within a specified timescale, together with a statement acknowledging completion of a periodic review by top management. An occasional independent overview of the checklist content and achievement of the Quality Assurance should be undertaken.

7.18.1.4 The small ATO may decide to use internal or external auditors or a combination of the two. In these circumstances it would be acceptable for external specialists and or qualified Organisations to perform the quality audits on behalf of the Quality Manger.

7.18.1.5 If the independent quality audit function is being conducted by external auditors, the audit schedule should be shown in the relevant documentation.

7.18.1.6 Whatever arrangements are made, the main ATO retains the ultimate responsibility for the quality system and especially the completion and follow-up of corrective actions.



Advisory Circular

TCAA-AC-OPS040B

February 2020

APPENDIX E

APPLICATION FOR AN APPROVED TRAINING ORGANISATION CERTIFICATE

APPLICATION FOR ISSUE OR RENEWAL OF AN APPROVED TRAINING ORGANISATION CERTIFICATE

SECTION 1

1. NAME AND ADDRESS OF ATO

(a) Name and mailing address of company (include business name if different from company name).

(b). Address of the principal (main) base where operations will be conducted.

(c) Name and address of Satellite 1

(d) Name and Address of Satellite 2

3. MANAGEMENT PERSONNEL

Name

Management Position

4. TYPES OF TRAINING COURSES AND LOCATION

Specific Training Course(s)

Training Location (Main Base or Satellite by Name)

5. Appendices

Details of proposed training curricula, training equipment, training facilities, qualifications of training and testing personnel, evaluation plans, record keeping system and quality control system are described in the following Appendices to this application as shown by the ticked box:

Subject

Appendix

Proposed Training Curricula/Syllabuses and Courseware

A



Advisory Circular

TCAA-AC-OPS040B

February 2020

<input type="checkbox"/> Training Equipment/Device	B
<input type="checkbox"/> Aircraft	C
<input type="checkbox"/> Training Facilities	D
<input type="checkbox"/> Qualifications of Instructors, Examiners and Quality Control Personnel	E
<input type="checkbox"/> Evaluation Plans	F
<input type="checkbox"/> Recordkeeping System	G
<input type="checkbox"/> Quality Control System	H

AC-OPS040



Advisory Circular

TCAA-AC-OPS040B

February 2020

APPENDIX E

6. ATTACHMENTS AND ADDITIONAL INFORMATION	
Accompanying Attachments	Attachment
<input type="checkbox"/> Training Procedures Manual	1
<input type="checkbox"/> List of Training functions	2
<input type="checkbox"/> Schedule of Events	3
<input type="checkbox"/> Statement of Compliance	4
<input type="checkbox"/> Documents of Purchase, Leases, Contracts or Letters of Intent	5
<input type="checkbox"/> Resumes of Management Personnel	6
<input type="checkbox"/> Vital information Data Forms	7
Additional Information:	
7. STATEMENT BY ACCOUNTABLE MANAGER	
<p>The details in this form, its Appendices and accompanying documents are in support of my (our) application for an Approved Training Organisation Certificate. I (We) shall notify the Authority within 10 working days of any change made in the assignment of persons to the required management positions in the ATO.</p>	
Name _____	Position _____ Signature _____ Date _____
Name _____	Position _____ Signature _____ Date _____
SECTION 2 - To be completed by the authority office.	
Acceptance or Denial	
<input type="checkbox"/> Application Accepted	<input type="checkbox"/> Application Denied - Reasons for Denial:
<p>Note: Acceptance of this application does not constitute approval or acceptance of individual Appendices or Attachments which will be evaluated during the certification phases.</p>	
Recommendations	



Advisory Circular

TCAA-AC-OPS040B

February 2020

Licensing Inspector _____ Signature _____ Date _____

Operations Inspector _____ Signature _____ Date _____

Airworthiness Inspector _____ Signature _____ Date _____

AC-OPS040

APPENDIX F

DEFINITIONS

“Accountable manager” means the manager who has corporate Authority for ensuring that all training can be financed and carried out to the standard required by the Authority;

“Advanced flight training device” means a flight training device which has a cockpit that accurately replicates a specific make, model, and type aircraft cockpit, and handling characteristics that accurately model the aircraft handling characteristics;

“Authorized instructor” means a person who holds a current flight instructor rating or a person who is authorized to provide ground training, flight simulator training or flight training in accordance with the provisions of the Regulations;

“Approved Training Organisation satellite” means a facility of an Approved Training Organisation at a location other than primary location of such Approved Training Organisation;

“Core curriculum” means a set of courses approved by the Authority, for use by an approved Approved Training Organisation and its satellite approved Approved Training Organisations consisting of training that is required for licensing or aircraft ratings but does not include training for tasks and circumstances unique to a particular user;

“Course” means a programme of instruction to obtain an airman licence, rating, qualification or authorization;

“Courseware” means instructional material developed for each course or curriculum, including lesson plans, flight event descriptions, computer software programmes, audio-visual programmes, workbooks and handouts;

“Curriculum” Curriculum is a specific course or courses of study or collectively; all the courses of study at an Approved Training Organisation. It may be identified as either a core or specialty curriculum. Components of a curriculum are called curriculum segments;

“Curriculum Segments” A curriculum segment is a subpart of a curriculum. It consists of a group of broadly-related training subjects and activities based on regulatory requirements. It is a portion of a curriculum that can be separately evaluated and approved. A segment is an integral part of a curriculum, but by itself it cannot qualify a person for a licence, rating or authorization. Some examples of segment are: systems integration training, flight simulator training periods, aircraft flight training periods, and aircraft ground training periods;

“Examiner” means a person designated by the Authority to conduct an aeronautical knowledge or other tests for which he is qualified;



Advisory Circular

TCAA-AC-OPS040B

February 2020

“Flight simulator” means a device that—

(a) is a full-size aircraft cockpit replica of a specific type, make model and series of aircraft;

(b) includes the hardware and software necessary to represent the aircraft in ground operations and flight operations;

“Flight training device” means an instrument that—

(a) is a full-size replica of the instrument, equipment, panels, and controls of an aircraft, open or in an enclosed cockpit, including the hardware and software for the systems installed, that is necessary to stimulate the aircraft in ground and flight operations;

(b) need not have a force cueing or visual system; and

(c) has been approved or accepted by the Authority;

“Flight training equipment” means a flight simulator, a flight training device and an aircraft;

“Level 1 Flight Training Specifications” means the specific approvals of a flight training facility that conducts all or substantially all of each flight training course using aircraft;

“Level 2 Flight Training Specifications” means the specific approvals of a flight training facility that conducts all or substantially all of each flight training course using simulation media that are qualified and approved by the Director General;

“Line-operational simulation” means simulation conducted using operational-oriented flight scenarios that accurately replicate interaction among flight crew members and between flight crew members and dispatch facilities, other crew members, air traffic control, and ground operations;

“Line orientation flight training” means flight training in a simulator with a complete crew using representative flight segments that contain normal, abnormal, and emergency procedures that may be expected in line operations;

“Specialty curriculum” means a set of courses designed to comply with the Act or Regulations made thereunder which is approved by the Authority for use at an Approved Training Organisation with Level 2 Flight Training Specifications;

“Syllabus” A syllabus is a set of subjects arranged in lesson format for delivery in a learning order sequence. It is not a part of a curriculum, but it is required for implementing a curriculum. Each syllabus must include scheduled hours, media and methods of delivery, as well as courseware;

“Training programme” means a programme that consists of courses, courseware, facilities, flight training equipment, and qualified personnel necessary to accomplish a specific training objective and may include a core curriculum and a specialty curriculum;



Advisory Circular

TCAA-AC-OPS040B

February 2020

“Training specifications” means a document issued to an approved Approved Training Organisation by the Authority that specifies the checking, testing authorizations, limitations and training programme requirements for such Organisation.

APPENDIX G Approved Training Organisation Certification Checklist and Schedule of Events CL: AC-OPS040

Office Name of Company		Location Address				
Mailing Address (if different from location)		Pre-certification Number:				
Authority Reference		Schedule Date	Inspector Initials	Date Received	Date Returned for Changes	Date Accomplished
I. Pre-application Phase						
A. Initial Orientation: Inspector:						
<ul style="list-style-type: none"> 1. Certification Advisory Circular provided to prospective ATO. 2. Prospective ATO Pre-assessment statement (PASI) – Forward to Director General CAA 						
B. Certification Team Designated						
	Name	Speciality				
P						
M						



Advisory Circular

TCAA-AC-OPS040B

February 2020

	<p>C. Conduct Pre-application Meeting</p> <ol style="list-style-type: none"> 1. <input type="checkbox"/> Verify PASI Information 2. <input type="checkbox"/> Overview of Certification Process 3. <input type="checkbox"/> Provide Certification Package: <ul style="list-style-type: none"> <input type="checkbox"/> Certification Checklist <input type="checkbox"/> Schedule of Events <input type="checkbox"/> Application Form <input type="checkbox"/> Other applicable publications and documents 4. Explain Formal Application Submissions 					
<p>Remarks:</p>						

APPENDIX G – Cont
Approved Training Organisation Certification Checklist and Schedule of Events
CL: AC-OPS040

Authority Reference	II. Formal Application Phase	Schedule d Date	Inspector Initials	Date Receive d	Date Returne d for Changes	Date Accomplis hed
	A. Review Applicant’s Submission					
	1. Formal Application Form					
	2. Formal Application Attachments					
	(a) Two completed Training Procedures Manuals					
	(b) List of Training Functions					
	(c) Initial compliance statement					
	(d) Completed schedule of events					
	(e) Records and qualifications of accountable manager, management positions, and training, testing and quality personnel					
	(f) Purchase, Lease, and/or contract agreement where applicable					
	(g) Vital Information Data Forms					



Advisory Circular

TCAA-AC-OPS040B

February 2020

	B. Evaluation of the Authority Resources Capability Based on Schedule of Events					
Remarks:						
	C. Formal Application Meeting Schedule of Events Date: _____ Time _____					
	1. Discuss each Submission					
	2. Resolve Discrepancies/ open Items					
	3. Review Certification Process					
	4. Review impact if SOE timings not met					
	D. Issue letter accepting/rejecting Formal Application					
Remarks:						

APPENDIX G – Cont
Approved Training Organisation Certification Checklist and Schedule of Events
CL: AC-OPS040

Authority Reference	III. Document Evaluation Phase	Scheduled Date	Inspector Initials	Date Received	Date Returned for Changes	Date Accomplished
	A. ATO Personnel:					
	1. Management Personnel					
	2. Examiners					
	3. Instructors					
	4. Quality Control Personnel					
	B. Required Documents:					
	1. Lease Agreements and Contracts					
	2. Training agreement with another ATO					
	3. Completed Application Form (ATO)					



Advisory Circular

TCAA-AC-OPS040B

February 2020

	4. Schedule of Events					
	5. Completed Compliance Statement					
	6. Draft training specifications					
	C. Evaluate Applicable Manual(s)					
	1. Completed Training Procedures Manual					
	2. Completed Quality Control Policy and Procedures Manual					
	D. Approved Programme for Maintenance and Inspection of Aircraft					
	1. MEL					
	2. Simulator Component Inoperative Guide (SCIG)					
	E. Simulators and Flight Training Devices					
	F. Training Programme					
	1. Core Curriculum					
	2. Specialty Curriculum					
	3. Courseware					
	4. Deviations and Waivers					
	5. Training Records					
Remarks:						

APPENDIX G – Cont

Approved Training Organisation Certification Checklist and Schedule of Events CL: AC-OPS040

Authority Reference	IV. Demonstration and Inspection Phase	Scheduled Date	Inspector Initials	Date Received	Date Returned for Changes	Date Accomplished
	A. Facilities and Equipment:					
	1. Training Facilities					
	2. Aircraft Used for Training					
	3. Equipment Used for Training					
	B. Record keeping Systems					
	C. Flight Simulators and FTD					
	D. Quality Control System					
	E. Observation of conduct of Actual Training					



Advisory Circular

TCAA-AC-OPS040B

February 2020

Remarks:

A Reference	V. Certification Phase	Scheduled Date	Inspector Initials	Date Receive d	Date Returne d for Changes	Date Accomplis hed
	A. Complete Form (ATO)					
	B. Prepare ATO Certificate					
	C. Prepare ATO Training specifications					
	D. Present signed ATO Certificate and Training specifications to ATO					

Remarks:



Advisory Circular

TCAA-AC-OPS040B

February 2020

APPENDIX H

Sample Statement of Compliance

STATEMENT OF COMPLIANCE				
Regulation.	TITLE	APPLY	TPM REF.	REMARKS
1	Citation	N	N/A	N/A
2	Interpretation	Y	TPM Sect 1, Ch 1, Pg 2	
3	requirement for an ATO certificate	Y	TPM Sect 1, Ch 2, Pg 1	
3	Evaluation and checking			
17(1)(a)	Nomination of an Accountable Manager	Y	TPM Sect 1, Ch 2, Pg 1	
17(1)	Staffing Requirements	Y	TPM Sect 1 Ch 2, Pg 2	
22(2)	Maintain facilities, equipment and material	Y	TPM Sect 1 Ch 2, Pg 3	
22(3)	Changes to facilities equipment or material	Y	TPM Sect 1 Ch 2, Pg 3	
				It is acknowledged that the DGCA may prescribe the conditions under which the ATO may operate while it is changing location



Advisory Circular

TCAA-AC-OPS040B

February 2020

APPENDIX I

Biographical Data

MANAGEMENT PERSONNEL BIOGRAPHICAL DATA (To be completed by the Nominee)		
1. Company name:	2. Company address:	
3. Name of nominee:	4. Position:	
5. Address of Nominee:		
6. Status: <input type="checkbox"/> Permanent <input type="checkbox"/> Contracted - Full Time <input type="checkbox"/> Contracted - Part Time		
7. Qualifications relevant to item (4) position (Tick here <input type="checkbox"/> if information is continued on reverse side of this form)	Date From	Date to
(1)		Present
(2)		
(3)		
(4)		
(5)		
(6)		
(7)		
(8)		
8. Work experience relevant to item (4) position:	Date From	Date to
(1)		Present
(2)		
(3)		
(4)		
(5)		
(6)		
(7)		
(8)		



Advisory Circular

TCAA-AC-OPS040B

February 2020

9. I,..... hereby confirm that
 (Print Name in full)

(a) I have not
 (i) held a certificate or aviation document issued by a civil aviation Authority that was revoked or terminated within the previous five years by reason of criminal, fraudulent, improper action or insanity on my part; nor
 (ii) contributed materially to the revocation or suspension of an aviation document issued by a civil aviation Authority

(b) The information provided on this form is true and correct to the best of my knowledge.

Signature:.....
 Date:.....

10. **For CAA Official Use Only**

Received by:

Name: Position:

Signature:.....
 Date:.....

Attach copies of certificates/proof of experience to this form in support of information supplied.

FORM: AC-OPS001B

APPENDIX I – Cont

7. Qualifications relevant to item (4) position (Continued from Page 1)	Date From	Date to
(9)		
(10)		
(11)		
(12)		
(13)		
(14)		
(15)		
(16)		
8. Work experience relevant to item (4) position:	Date From	Date to
(9)		



Advisory Circular

TCAA-AC-OPS040B

February 2020

(10)		
(11)		
(12)		
(13)		
(14)		
(15)		
(16)		

9. I,..... hereby confirm that
(Print Name in full)

- (a) I have not
 - (i) held a certificate or aviation document issued by a civil aviation Authority that was revoked or terminated within the previous five years by reason of criminal, fraudulent, improper action or insanity on my part; nor
 - (ii) contributed materially to the revocation or suspension of an aviation document issued by a civil aviation Authority
- (b) The information provided on this form is true and correct to the best of my knowledge.

Signature:.....
Date:.....



Advisory Circular

TCAA-AC-OPS040B

February 2020

APPENDIX J Sample Training specifications

TABLE OF CONTENTS	
AVIATION TRAINING ORGANISATION	
TRAINING SPECIFICATIONS	EFFECTIVE DATE
A001 Issuance and Applicability	
A002 Definitions and Abbreviations	
A003 Aircraft Authorizations	
A004 Summary of Special Authorizations and Limitations	
A005 Exemptions and Deviations	
A006 Management Personnel	
A007 Agent for Service and Training Specifications Signatures	
A008 Satellite Training Locations	
A009 Reserved	
A012 Examiners	
A013 Instructors	
A015 Flight Simulator Authorizations	
A016 Flight Training Devices	
A025 Approved Recordkeeping Systems	
A031 Training Agreements	
B001 Approved Curricula (Other than ATPL Aeroplane)	
B002 ATPL and Added Aircraft Type Rating (Aeroplane)	
B003 Flight Instructor Approved Curricula	
B004 Airmen Certification other than pilot	
B008 Satellite Training Organisation Operation Na Authorizations	
B009 Reserved	
B011 Approved Curricula other than Airline Rotorcraft/Helicopters	
B012 ATPL and Added Aircraft Type Rating (Rotorcraft/helicopter)	
B031 Training Agreement Authorizations and Limitations	
C075 Circling Approach Procedures	
D001 Aeroplane Maintenance Requirements	
D002 Level A and B Flight Simulator Maintenance Requirements	
D003 Level C Flight Simulator Maintenance Requirements	
D004 Level D Flight Simulators	
D071 FTD Maintenance Requirements	
D073 Aircraft Inspection Programmes	
D095 Minimum Equipment List (MEL) Authorization	
D096 Simulator Component Inoperative Guide Authorization.	
Effective Date _____	Approved Training Organisation Certificate No. _____



Advisory Circular

TCAA-AC-OPS040B

February 2020

APPENDIX J – Cont

A001 SAMPLE OPERATION SPECIFICATION A001

Authority Control:

Civil Aviation Authority

Training Specifications

Authority Revision:

A001. Issue and Applicability

a. These training specifications are issued to ABC Approved Training Organisation who shall hereafter be referred to as ABC. ABC’s principal place of business is located at:

Primary Business Address:

Samora/Azikiwe Street
Nairobi
Kenya

Mailing Address:

P.O. Box 2819
Nairobi
Kenya

Contact Information

Telephone Number	Facsimile Number	TELEX Number:	E-Mail Address:

ABC is the holder of Approved Training Organisation Certificate Number ABC-123. These training specifications are issued in accordance with Regulations 5(6) and 13(2) of the Civil Aviation (Approved| Training Organisation) Regulations. ABC shall conduct operations in accordance with the specific| authorizations, limitations, and the procedures in these training specifications, and all appropriate Regulations.

b. ABC is authorized to conduct pilot training, testing and checking for the issue by the Authority of pilot licences ratings and authorizations under The Civil Aviation (Personnel Licensing) Regulations, as| shown in Table 1.

Table 1

CIVIL AVIATION REGULATIONS		
Training	Testing	Checking
PEL Part VI	PEL Part VI	PEL Part VI

c. ABC is authorized to use only the business name which appears on the certificate to conduct the operations described in subparagraph A

d. These training specifications are effective from the "Effective Date" shown in each paragraph of these training specifications, and shall remain in effect as long as ABC continues to meet the KCAR requirements specified for certification unless sooner suspended, surrendered, amended or revoked.



Advisory Circular

TCAA-AC-OPS040B

February 2020

APPENDIX J – Cont

SAMPLE OPERATION SPECIFICATION A003

Civil Aviation Authority	Authority Control:	Authority Revision:
A003. Aircraft Authorization	Training Specifications	

a. ABC is authorized to conduct training, testing, and/or checking, as authorized in its Training Procedures Manual, in the following aircraft owned or leased by ABC:

Registration #	Aircraft M/M/S	Owned or Leased
5H-MJM	Cesna/172/310	owned

b. ABC is authorized to conduct training, testing, and/or checking, as authorized in its Training Procedures Manual, in the following aircraft that are registered to, and maintained by the holder of an air operator certificate:

Aircraft M/M/S	Air Operator
Cessna/172/310	ABC



Advisory Circular

TCAA-AC-OPS040B

February 2020

APPENDIX J – Cont

Sample Training specifications (Authorization Page)

The certificate number on the reverse side of this form identifies the Approved Training Organisation whose name appears in Part A-001 of these Training Specifications.

1. The Civil Aviation Authority issues the Training Specifications on the reverse side to ABC.
2. ABC hereby makes application for the ATO's training specifications appearing on the reverse side hereof, (if this application amends previously approved training specifications, tick the amendment box below and briefly describe the changes in the space below)

INITIAL ISSUE

AMENDMENT

Reasons and supporting data for amendment (if space insufficient attach additional pages as required)

I certify that the statements submitted as supporting data are true and I am duly authorized to make this application on behalf of ABC

Name and Title

Signature

Date

3. The Training Specifications set forth on the reverse side are approved by the Authority.

4. Name of Inspector: _____ Signature _____ Date: _____
For: The Director General

5. Effective Date of Approval: _____ Amendment No.: _____



Advisory Circular

TCAA-AC-OPS040B

February 2020

6. I hereby accept and receive the Training Specifications appearing on the reverse side on behalf of ABC Approved Training Organisation.

Name and Title

Signature

Date

Director Safety Regulation